

## HS 8136-HS 8168 Präzisions Seitenschneider ESD mit spitz zulaufendem, abgeflachtem Kopf

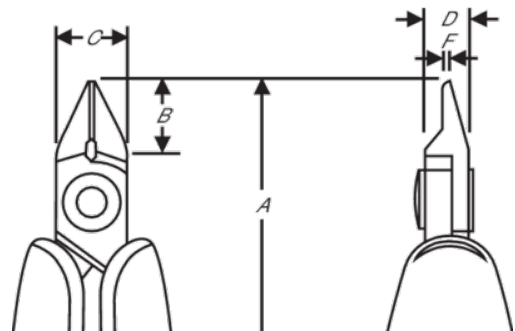

### PRODUKTDDETAILS

- Präzisions Seitenschneider mit spitz zulaufendem, abgeflachtem Kopf, HS-Serie
- Weiche ESD-sichere Schaumstoffgriffe mit Öffnungsfeder
- Schnittformen: Micro-bevel (mit Wate), flush (kleine Wate) & ultra-flush (ohne Wate)
- Angabe der Schneidkapazität bezieht sich auf Kupfer
- Geeignet zum Schneiden von Kupferdrähten
- Werkstoff: Hochleistungs-Stahllegierung
- Phosphatiert
- Präzisionsgeschliffene Schneidkanten für eine besonders lange Lebensdauer und einen sauberen Schnitt
- Induktionsgehärtete Schneiden mit einem hohen Härtegrad (63-65 HRC)
- Reibungsmindernde Schraubverbindung für glatte Schnitte ohne Überlappen der Schenkel
- Ideal für Arbeiten an Kabelsträngen und Leiterplatten



# PRODUKTEIGENSCHAFTEN

Produkt: **HS8136**

	Tapered & Relieved		XS		Micro-Bevel®
	0.1-0.8 mm		0.004-0.03 in		140.3 mm
	5.52 in		8 mm		0,31 in
	8 mm		0.31 in		5 mm
	0,2 inch		0,8 mm		0,03 in
	91 g		Dissipative		

Produkt: **HS8137**

	Tapered & Relieved		XS		Flush
	0.1-0.8 mm		0.004-0.03 in		140.3 mm
	5.52 in		8 mm		0,31 in
	8 mm		0.31 in		5 mm
	0,2 inch		0,8 mm		0,03 in
	91 g		Dissipative		

Produkt: **HS8138**

	Tapered & Relieved		XS		Ultra-Flush®
	0.1-0.5 mm		0.004-0.02 in		140.3 mm
	5.52 in		8 mm		0,31 in
	8 mm		0.31 in		5 mm
	0,2 inch		0,8 mm		0,03 in
	91 g		Dissipative		

Produkt: **HS8146**

	Tapered & Relieved		S		Micro-Bevel®
	0.2-1.0 mm		0.01-0.04 in		5.60 mm
	142.3 in		10 mm		0,39 in
	10 mm		0.39 in		6 mm
	0,24 inch		0,8 mm		0,03 in
	91 g		Dissipative		

Produkt: **HS8147**

	Tapered & Relieved		S		Flush
	0.1-1.0 mm		0.01-0.04 in		5.60 mm
	142.3 in		10 mm		0,39 in
	10 mm		0.39 in		6 mm
	0,24 inch		0,8 mm		0,03 in
	91 g		Dissipative		

Produkt: **HS 8148**

	Tapered & Relieved		S		Ultra-Flush®
	0.1-0.8 mm		0.01-0.03 in		5.60 mm
	142.3 in		10 mm		0,39 in
	10 mm		0.39 in		6 mm
	0,24 inch		0,8 mm		0,03 in
	90 g		Dissipative		

Produkt: **HS8156**

	Tapered & Relieved		M		Micro-Bevel®
	0.3-1.25 mm		0.01-0.05 in		144.8 mm
	5.70 in		12,5 mm		0,5 in
	12,5 mm		0.49 in		6 mm
	0,24 inch		1 mm		0,04 in
	97 g		Dissipative		

Produkt: **HS8157**

	Tapered & Relieved		M		Flush
	0.2-1.25 mm		0.01-0.05 in		144.8 mm
	5.70 in		12,5 mm		0,5 in
	12,5 mm		0.49 in		6 mm
	0,24 inch		1 mm		0,04 in
	97 g		Dissipative		

Produkt: **HS8158**

	Tapered & Relieved		M		Ultra-Flush®
	0.2-1.0 mm		0.01-0.04 in		144.8 mm
	5.70 in		12,5 mm		0,5 in
	12,5 mm		0.49 in		6 mm
	0,24 inch		1 mm		0,04 in
	97 g		Dissipative		

Produkt: **HS8166**

	Tapered & Relieved		L		Micro-Bevel®
	0.4-1.5 mm		0.02-0.06 in		125 mm
	4.92 in		16 mm		0,63 in
	16 mm		0.63 in		8 mm
	0,31 inch		1,6 mm		0,06 in
	139 g		Dissipative		

Produkt: **HS8167**

	Tapered & Relieved		L		Flush
	0.3-1.5 mm		0.01-0.06 in		125 mm
	4.92 in		16 mm		0,63 in
	16 mm		0.63 in		8 mm
	0,31 inch		1,6 mm		0,06 in
	139 g		Dissipative		

Produkt: **HS8168**

	Tapered & Relieved		L		Ultra-Flush®
	0.3-1,25 mm		0.01-0.05 in		125 mm
	4.92 in		16 mm		0,63 in
	16 mm		0.63 in		8 mm
	0,31 inch		1,6 mm		0,06 in
	139 g		Dissipative		